

# DOXI VALVES

A MEMBER OF  XUANDA GROUP



# Butterfly Valve

**DOXI**

Lined butterfly valve

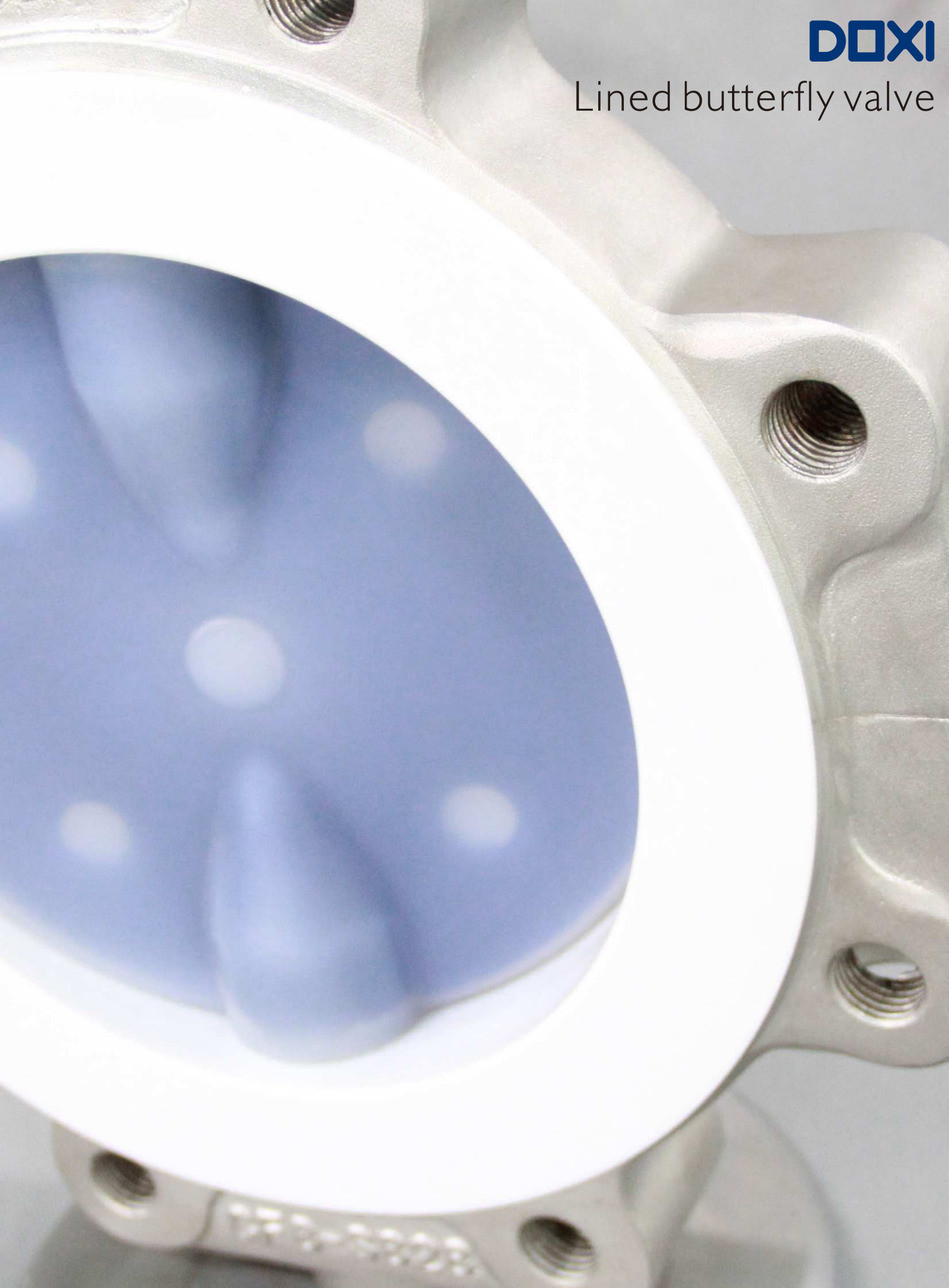

## Lined butterfly valve

DOXI

Size	50mm~900mm (2"-36")
Working pressure	0.1mbar~10bar
Temperature range	-20° C ~ 200° C according to working conditions, other temperatures on request.
Design and Manufacture	API609 DIN EN1092 JIS B2032
Face to Face	ASME B16.10 DIN EN558. 1 JIS B2002
Flange Ends	ASME B16.5 DIN 2532 JIS B2212 (150lb, 10k, Pn10)
Visual Inspection	MSS Sp54
Testing	API 598 DIN 3230 JIS B2003
Pressure & Temperature	ASME B16.34
Operator Type	Lever/ Gear/ Pneumatic/ Electric
Spark testing	14kv



### ■ Lined butterfly valve

The DOXI butterfly valves'special feature is the seat ring design. The interference between the disc and the raised central area of the seat ring shuts off the flow completely. The resilient elastomeric seat cushion ensures reliable shut-off for the life of the valve.

The upper and lower positions of the seal ring, where the stem passes through, use a triple seal design to prevent leakage to the atmosphere.

Triple Seal Prevent Leakage

Primary Seal: ① Seat.

Secondary Seal: ② O ring

Tertiary Seal: ③ Taper PTFE seal ring

Stem design (Square, double-D, single key ,double key)

Self lubricating bushing could endure under pressure and three point form SL design could prevent disc be deformed

Double belleville springs exert uniform loading through the pusher, pressing the PTFE seal ring and the shoulder of the disc hub together resulting in a leak free mechanical stem seal

O-ring (the second seal)

Elastomer back-up immersed in body ensures zero leakage between disc and seat.

Two piece body (wafer and lug type)precision casting moulds with clear mark.

ISO5211 pad universal mounting permits easy automations even with the valves in the pipe line

Integral body locating holes to ensure perfect centering of the valves between flange. Applied to different international standard

PTFE seat Precision machinery processing, extra wide spheroidal seat design provides positives shut off (the primary seal)

Taper metal seal cartridge (the third seal)

Taper PTFE sealing seal

One piece disc-stem, blow out-proof machined.Rated for full vacuum and thermal cycling. Minimum lined thickness 3mm eliminates permeations and possible delamination

Epoxy coating paint with baked finished

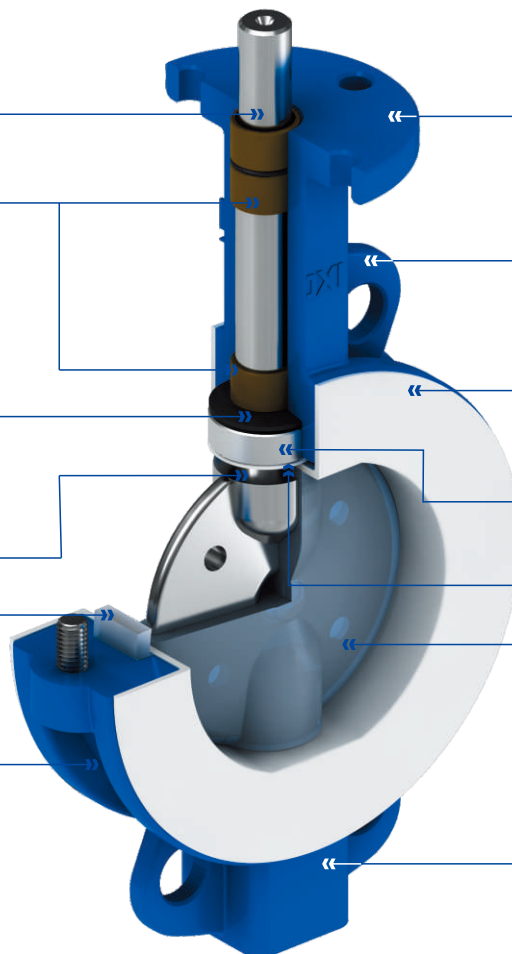

# Lined butterfly valve

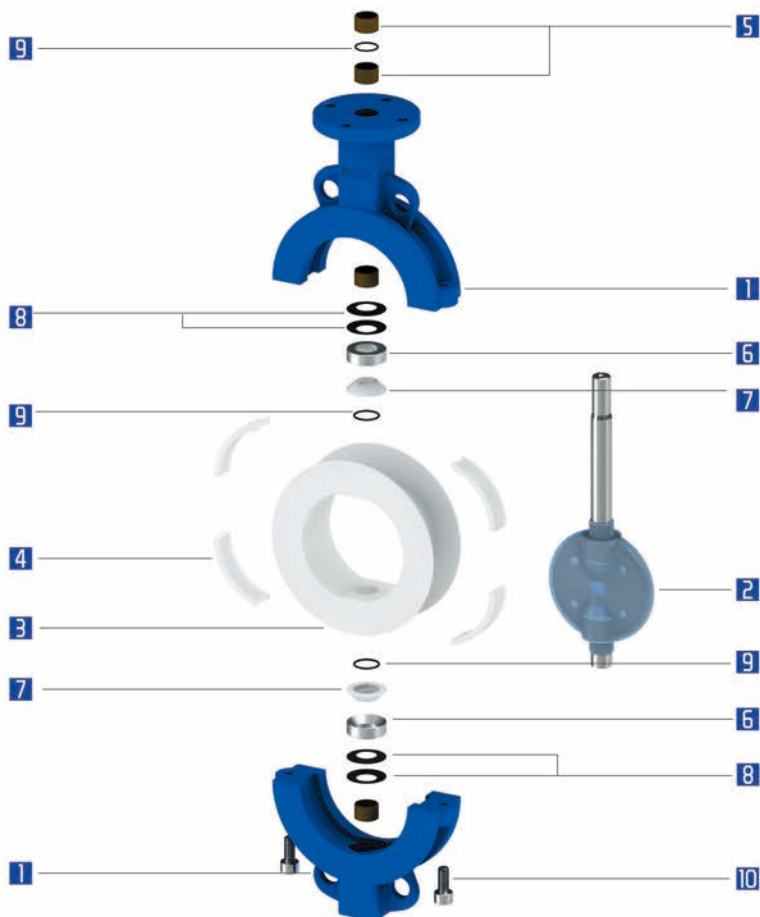

## MATERIALS SELECTION

No	Description	Qty.	Materials	Materials According to Norms		
				ASTM	JIS	DIN
1	BODY	2	Carbon Steel	A216-WCB	G5151 SCPH2	GS-45(1.0446)
			Stainless Steel	A351-CF8	G5121 SCS13A	G-X6CrNiMo1810
			Ductile Iron	ASTM A395	FCD400	GGG-40 ( 0.7040)
2	ONE-PIECE DISC	1	Carbon Steel	A216-WCB	G5151 SCPH2	GS-45(1.0446)
			Stainless Steel	A351-CF8	G5121 SCS13A	G-X6CrNiMo1810
			Ductile Iron	A536-60-40-18	FCD350-22	1693-1997GGG-35.3(0.7033)
3	BODY LINER(SEAT)	1	PTFE/UHMWPE/PO/PE/FEP/PFA	-	-	-
4	ELASTIC SPACER	2	Silicone Rubber	-	-	-
5	AXLE SLEEVE	4	Carbon Steel+PTFE	1020+PTFE	S20C+PTFE	C20+PTFE
6	TAPER SEAL CARTRIDGE	2	Carbon Steel	1020	S20C	C20
7	TAPER SEAL RING	2	PTFE	-	-	-
8	BELLEVILLE SPRING	4	Spring Steel	E52100	Su52	100Cr6
9	O-RING	3	VITON	-	-	-
10	HEX BOLT	2	Stainless Steel	A 182 F304	G4303-SUSF304	X5CrNi18 10 DIN 17440

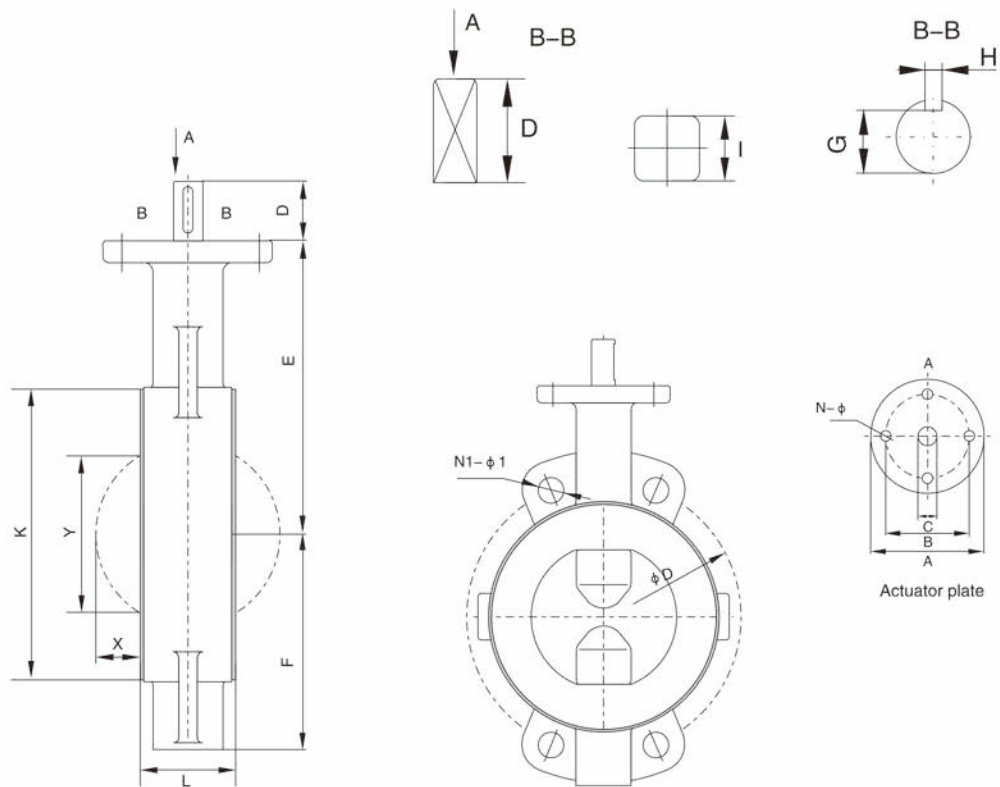

## WAFER TYPE DIMENSION

DN NPS		Dimensions in mm														A	ASME 150LB		JIS 10K		DIN Pn10		Weight	Torque	
mm	in	A	B	C	D	E	F	G	H	I	N-φ	L	K	X	Y	ISO 5211	φD	N1-φ1	φD	N1-φ1	φD	N1-φ1	[Kg]	CV	[N·m]
50	2	77	57	12.6	23	115	60	/	/	11	4-10	52	100	9	42	F07	120.7	4-19	120	4-19	125	4-18	2.2	210	25
65	1½	77	57	12.6	23	115	60	/	/	11	4-10	52	100	9	42	F07	139.7	4-19	140	4-19	145	4-18	2.2	210	25
80	3	92	70	12.6	26	150	86	/	/	11	4-10	46	135	18	66	F07	152.4	4-19	150	8-19	160	4-18	4.2	410	50
100	4	92	70	15.9	26	160	115	/	/	14	4-10	52	158	25	85	F07	190.5	8-19	175	8-19	180	8-18	6.4	710	80
125	5	92	70	15.9	26	175	130	/	/	14	4-10	56	185	35	112	F07	215.9	8-22	210	8-23	210	8-18	7.9	1150	90
150	6	115	89	22.2	28	192	145	/	/	17	4-14	56	210	48	139	F07	241.3	8-22	240	8-23	240	8-23	10.4	1750	130
200	8	115	89	22.2	28	220	175	/	/	17	4-14	60	263	69	187	F10	298.5	8-22	290	12-23	295	8-23	17	3550	180
250	10	140	108	31.8	35	275	215	/	/	24	4-14	68	320	90	237	F10	362	12-25	355	12-25	350	12-23	25	5100	400
300	12	140	108	31.8	35	310	250	/	/	24	4-14	78	368	112	290	F12	431.8	12-25	400	16-25	400	12-23	34.5	8870	610
350	14	210	165	38	55	360	285	33	10	/	4-22	78	410	136	341	F14	476.3	20-1 3/8	445	16-25	460	16-23	75	9200	850
400	16	210	165	38	55	395	320	33	10	/	4-22	102	460	147	383	F14	539.8	20-1 1/4	510	16-27	515	16-27	110	14500	1170
450	18	210	165	44	65	435	360	38.5	14	/	4-22	114	518	167	432	F14	577.9	16-1 1/4	565	20-27	/	/	130	20100	1560
500	20	210	165	44	65	435	385	38.5	14	/	4-22	127	565	181	473	F14	635	16-1 1/8	620	20-27	620	20-27	190	22000	1820
600	24	210	165	55	75	525	445	49	16	/	4-22	154	658	218	569	F14	749.3	12-1 1/8	730	24-33	725	20-30	280	31000	2990

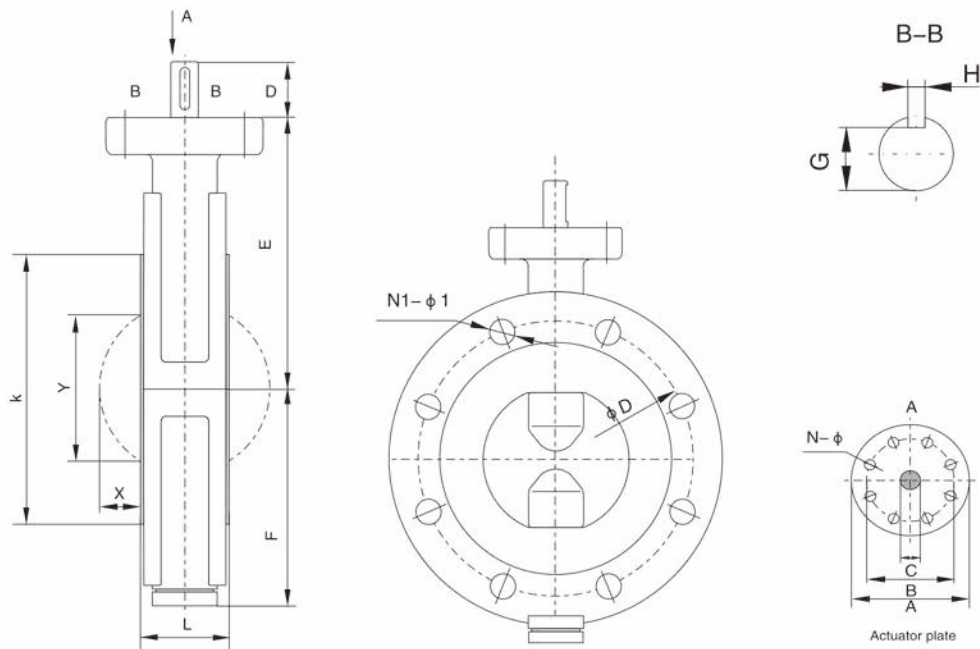

## WAFER TYPE DIMENSION

DN NPS		Dimensions in mm													A	ASME 150LB	JIS 10K	DIN Pn10		Weight	Torque			
mm	in	A	B	C	D	E	F	G	H	N-φ	L	K	X	L	ISO 5211	φD	N1-φ1	φD	N1-φ1	φD	N1-φ1	[Kg]	CV	[N · m]
700	28	300	254	70	120	670	550	55	20	8-19	165	780	268	680	F25	795.3	40-7/8	840	24-33	840	24-30	320	39500	3500
800	32	300	254	70	120	750	600	55	20	8-19	190	885	295	756	F25	900.1	48-7/8	950	28-33	950	24-33	395	51750	4500
900	36	300	254	85	120	790	630	67	22	8-19	203	990	344	867	F25	1010	44-1	1050	28-33	1050	28-33	450	63600	5500

# Lined butterfly valve

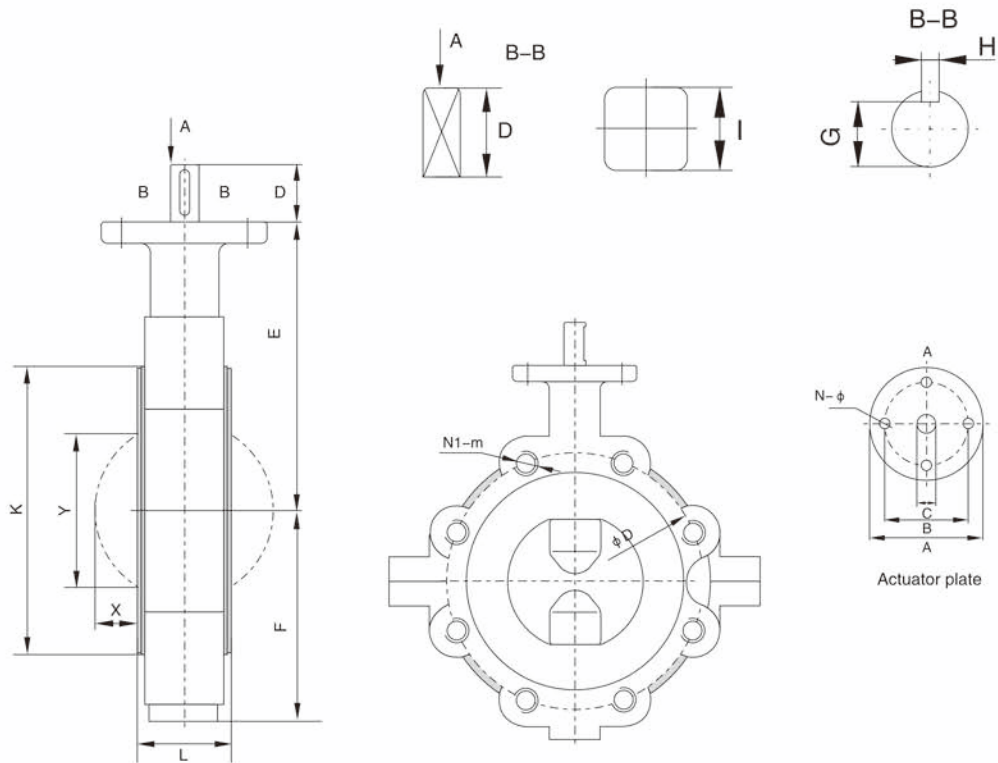

## LUG TYPE DIMENSION

DN NPS		Dimensions in mm														A	ASME B16.5		JIS B2212 10K		DIN2532 Pn10		Weight		Torque
mm	In	A	B	C	D	E	F	G	H	I	N-φ	L	K	X	Y	ISO 5211	φD	N1-m	φD	N1-m	φD	N1-φ1	[Kg]	CV	[N-m]
50	2	77	57	12.6	23	115	60	/	/	11	4-10	52	100	9	42	F07	120.7	4-5/8	120	4-16	125	4-M16	2.9	210	25
65	2½	77	57	12.6	23	115	60	/	/	11	4-10	52	100	9	42	F07	139.7	4-5/8	140	4-16	145	4-M16	2.9	210	25
80	3	92	70	12.6	26	150	86	/	/	11	4-10	46	135	18	66	F07	152.4	4-5/8	150	8-16	160	8-M16	5.5	410	50
100	4	92	70	15.9	26	160	115	/	/	14	4-10	52	158	25	85	F07	190.5	8-5/8	175	8-16	180	8-M16	8.3	710	80
125	5	92	70	15.9	26	175	130	/	/	14	4-14	56	185	35	112	F07	215.9	8-3/4	210	8-20	210	8-M16	10.3	1150	90
150	6	115	89	22.2	28	192	145	/	/	17	4-14	56	210	48	139	F07	241.3	8-3/4	240	8-20	240	8-M20	13.5	1750	130
200	8	115	89	22.2	28	220	175	/	/	17	4-14	60	263	69	187	F10	298.5	8-3/4	290	12-20	295	8-M20	22.1	3550	180
250	10	140	108	31.8	35	275	215	/	/	24	4-14	68	320	90	237	F10	362	12-7/8	355	12-22	350	12-M20	32.5	5100	400
300	12	140	108	31.8	35	310	250	/	/	24	4-14	78	368	112	290	F12	431.8	12-7/8	400	16-22	400	12-M20	44.9	8870	610
350	14	210	165	38	55	360	285	33	10	/	4-22	78	410	136	341	F14	476.3	12-1	445	16-22	460	16-M20	97	9200	850
400	16	210	165	38	55	395	320	33	10	/	4-22	102	460	147	383	F14	539.8	16-1	510	16-24	515	16-M24	143	14500	1170
450	18	210	165	44	65	435	360	38.5	14	/	4-22	114	518	167	432	F14	577.9	16-1 1/8	565	20-24	/	/	169	20100	1560
500	20	210	165	44	65	435	385	38.5	14	/	4-22	127	565	181	473	F14	635	20-1 1/8	620	20-24	620	20-M24	247	22000	1820
600	24	210	165	55	75	525	445	49	16	/	4-22	154	658	218	569	F14	749.3	20-1 1/4	730	24-30	725	20-M27	365	31000	2990